

GE

Measurement & Control

# RPS/DPS 8200/8300

## High Accuracy Resonant Pressure Sensor for Harsh Media



For over 40 years, Druck has manufactured precision pressure sensors with a capability to meet critical applications in industrial, aerospace, oil and gas, and research environments. Today, Druck is part of GE Measurement & Control and has continually worked to develop and improve on the performance of our pressure sensors to meet customer's requirements.

The RPS/DPS 8200/8300 moves the exciting new TERPS technology into harsh media environments. TERPS is a resonant silicon pressure sensor technology platform that provides an order of magnitude greater accuracy and stability than current pressure measurement technologies available. The new TERPS technology also extends the pressure range capability to high pressures and by incorporating true pressure media isolation greatly improves its suitability for use in harsh environments.

By packaging TERPS technology in Hastelloy C276, the RPS/DPS 8200/8300 allows for use in harsh corrosive media such as sea water, or sour gas.

The combination of the power of the TERPS technology and the quality, reliability and flexibility of the RPS/DPS 8000 Series offer a truly unique solution for high accuracy and high stability pressure measurement requirements.

### Features:

- High Precision,  $\pm 0.01\%$  FS over compensated temperature range
- High Stability,  $\pm 100$  ppm FS/year
- Wide temperature range,  $-40^{\circ}\text{C}$  to  $+125^{\circ}\text{C}$  ( $-40^{\circ}\text{F}$  to  $257^{\circ}\text{F}$ )
- Media isolated construction, suitable for use in harsh environments
- Multiple Output configurations, RS-232, RS-485, Frequency & Diode (TTL)
- Selection of pressure & electrical connections to suit specific requirements



GE imagination at work

# Specifications

## Measurement

### Pressure Ranges

- 0 to 2 bar (0 to 30 psi) absolute
  - 0 to 7 bar (0 to 100 psi) absolute
  - 0 to 14 bar (0 to 200 psi) absolute
  - 0 to 20 bar (0 to 300 psi) absolute
  - 0 to 35 bar (0 to 500 psi) absolute
  - 0 to 70 bar (0 to 1000 psi) absolute
- (Values in psi are approximate.)

The lowest calibrated pressure is 35 mbar absolute.

### Overpressure

1.5X FS

### Sensor Failure Pressure

2.0X FS

### Pressure Containment

- Ranges to 7 bar, (100 psi), 70 bar (1,000 psi)
- Ranges to 70 bar (1,000 psi), 200 bar (3,000 psi)

## Supply and Output

Electronics Option	Supply Voltage (V)	Output	Current Consumption*** (mA)
0	6 to 28	Frequency <sup>^</sup> & Diode <sup>^^</sup> (Low Power)*	3.5
1	6 to 28	Frequency <sup>^</sup> & Diode <sup>^^</sup> (Low Noise)**	10
A	11 to 28	RS485	16.5 quiescent, 32 max
B	11 to 28	RS232	16.5 quiescent, 32 max

\* Low Power has Jitter of <120 ns

\*\* Low Noise has Jitter of <75 ns

\*\*\* At 25°C (77°F)

<sup>^</sup> Square wave pressure signal, 25 kHz nominal, 4-10 kHz span

<sup>^^</sup> Forward voltage diode, 0.5 to 0.7 V @ 25°C (77°F), typically -2 mV/°C nominal

### Response Time

< 300 msec for pressure change from 10% to 90% FS

### Supply Response

Frequency & Diode: Accurate to specification within 500 ms of supply switch on, over all operating temperatures  
RS 232/485: First stable reading within 20 sec of supply switch on

### Electrical Protection

Connecting  $V_{supply}$  and GND between any combinations of pins on the connector will not damage the unit

### Insulation

500 V dc

## Performance

There are two levels of performance specification: standard and Improved.

Specifications include combined effects of non-linearity, hysteresis, repeatability and temperature errors over the compensated temperature range, and over the pressure range 35 mbar to the full scale pressure.

Accuracy Code	Precision
A1- Standard	0.02% FS
A2- Improved	0.01% FS

For Frequency & Diode output the above accuracies are achievable by using a polynomial curve fit algorithm and coefficient data supplied with sensor.

Sensors are calibrated against standards traceable to UKAS operating to better than 100 ppm.

### Compensated Temperature Ranges:

There are three compensated temperature ranges available:

-10 to +50°C

-40 to +85°C

-40 to +125°C

### Temperature Effects

All temperature effects are included in the accuracy statement.

### Long Term Stability

Standard:  $\pm 0.02\%$  FS/annum

Improved:  $\pm 0.01\%$  FS/annum

*Note: Unless otherwise specified, specifications are at reference conditions: 25°C (77°F)  $\pm 5^\circ\text{C}$  ( $\pm 9^\circ\text{F}$ ).*

### Orientation (g) Sensitivity

Less than 0.2 mbar/g

## Physical Specifications

### Storage Temperature Range

As operating temperature range.

### Operating Temperature Range

See electrical connector section

### Pressure Media

Media compatible with Hastelloy C276

### Ingress Protection

See Electrical Connector Section

## Vibration

DO-160E Curve W Sine sweeps 5 Hz to 2 kHz, levels to  $20g_n$   
 $<0.2 \text{ mbar}/g_n$  ( $<0.003 \text{ psi}/g_n$ ) output change

## Shock

DO-160E 9 (Figure 7.2)  $20 g_n$  11 ms terminal saw-tooth profile  
 Negligible calibration change

## Humidity

MIL-STD-810D Method 507.2 Procedure III (Aggravated humidity environment,  $65^\circ\text{C}$ , 95% RH)

## Pressure Connector

Available Options are

- G1/4 Female
- G1/4 Male Flat
- 1/4 NPT Female
- 1/4 NPT Male
- Depth Cone (G1/4 Female)

Please ensure that only the intended sealing face is used when mounting the sensor. Failure to comply with this requirement may affect performance or calibration accuracy.

Male threaded pressure connectors must not be sealed or constrained against the face at the base of the thread. The forward cone or flat face should always be used, as indicated below.

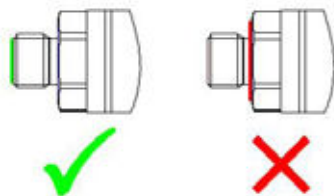

## Electrical Connector

Code Number	Description	Max Operating temp range		IP rating
		$^\circ\text{C}$	$^\circ\text{F}$	
0	No Connector	-55 to +125	-67 to +257	-
3	Polyurethane Depth	-40 to +80	-40 to +176	68
4	Hytrel Depth	-40 to +80	-40 to +176	68

## Certification

- CE Marked
- RoHS
- EMC Standards

BS EN 61000-6-1: 2007 Susceptibility - Light Industrial  
 BS EN 61000-6-2: 2005 Susceptibility - Heavy Industrial  
 BS EN 61000-6-3: 2007 Emissions - Light Industrial  
 BS EN 61000-6-4: 2007 Emissions - Heavy Industrial  
 BS EN 61326-1: 2006 Electrical Equipment for Measurement, Control and Laboratory Use - EMC requirements  
 BS EN 61326-2-3:2006 Requirements for pressure transducers

## Connection Details

Option	Code	Connection	Function		
			Frequency & Diode	Digital-RS485	Digital-RS232
Flying Leads	0	RED	SUPPLY +VE	SUPPLY +VE	SUPPLY +VE
		YELLOW	FREQ	RS485 B	Rx
		GREEN	+VE TEMP	RS485 A	Tx
		BLUE	GROUND	GROUND	GROUND
		ORANGE	EEPROM	-	-
		BLACK	-VE TEMP	-	-
CABLE	3, 4,	RED	SUPPLY +VE	SUPPLY +VE	SUPPLY +VE
		YELLOW	FREQ	RS485 B	Rx
		BLUE	+VE TEMP	RS485 A	Tx
		WHITE	GROUND	GROUND	GROUND
		ORANGE	EEPROM	-	-
		BLACK	-VE TEMP	-	-
		SCREEN	-	-	-
		-	-	-	-
		-	-	-	-

## Mechanical Drawings

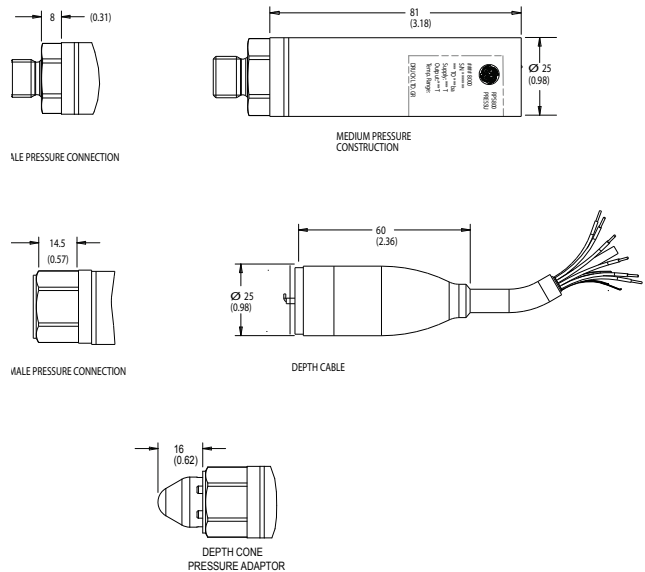

### Notes:

1. All dimensions are nominal lengths and are subject to change.
2. All dimensions are in millimeters (inches).
3. Other pressure and electrical connectors may be available, please contact GE.

**(1) Select model number**

**Main Product Variant**

**RPS** Resonant Pressure Sensor - Frequency & Diode Output **(Note 1)**  
**DPS** Digital Pressure Sensor - Digital Output **(Notes 1 and 2)**

**Product Series**

**8** RPS/DPS 8000 Series

**Diameter, Material and Isolation**

**2** 25mm Oil isolated Hastelloy Wetted Parts  
**3** 25 mm Oil isolated all Hastelloy

**Electrical Connector**

**0** No Electrical Connector (Flying leads)  
**3** Polyurethane Cable (Depth) IP68 **(Note 2)**  
**4** Hytrel Cable (Depth) IP68 **(Note 2)**

**Output Option**

**0** Frequency & Diode (Low Power <3.5 mA)  
**1** Frequency & Diode (Low Jitter approx 75 ns)  
**A** RS485 **(Note 2)**  
**B** RS232 **(Note 2)**

**Compensated Temperature Range**

**TA** -10 to +50 °C  
**TB** -40 to +85 °C  
**TC** -40 to +125 °C

**Accuracy**

**A1** - Standard 0.02%  
**A2** - Improved 0.01%

**Calibration**

**CC** Full Thermal Calibration

**Hazardous Area Approval**

**H0** None

**Pressure Connector**

**PA** G1/4 Female  
**PB** G1/4 Male Flat  
**PE** 1/4 NPT Female  
**PF** 1/4 NPT Male  
**PW** Depth Cone (G1/4 Female)

**R** **8** **2** **4** **1** - **TA** - **A2** - **CC** - **H0** - **PA** **Typical Model Number**

*Note 1: RPS variants require Output Option Code '0' or '1'. DPS variants require Output Option Code 'A' or 'B'.*

*Note 2: Compensated temperature range -40 to +125°C (TC) is not available with this option.*

**2) State pressure range (2, 7, 14, 20, 35 or 70 bar or equivalents) and units: e.g., 0 to 20 bar, 0 to 100 psi**

Unit options are:

Symbol	Description
bar	bar
mbar	millibar
psi	pounds/sq. inch
Pa	Pascal
hPa	hectoPascal
kPa	kiloPascal
MPa	megaPascal
mmH <sub>2</sub> O	mm water
cmH <sub>2</sub> O	cm water
mH <sub>2</sub> O	metres water
inH <sub>2</sub> O	inches water
ftH <sub>2</sub> O	feet water
mmHg	mm mercury
inHg	inches mercury
kgf/cm <sup>2</sup>	kg force/sq. cm
atm	atmosphere
Torr	torr

**3) State cable lengths and units: e.g. 1 m cable, 3 ft cable (only required on certain electrical connectors)**

**Typical order examples:**

RPS 8301-TC-A2-CC-H0-PA,70 bara  
 DPS 823A-TA-A1-CC-H0-PW, 2 bara, 10 m cable



[www.ge-mcs.com](http://www.ge-mcs.com)

920-602A